

Water mill sauna

The new water mill sauna is suitable for both permanent infusion for high humidity sauna bath and "infusionevent" at definite times in Finnish sauna.

A permanent infusion is taking place while the wheel is turning clockwise.

When turning counter clockwise no infusion is effected.

Available for capacities of: 18, 27 und 36 kW.

Total height: approx.. 1,70 m

Width of sauna heater: approx. 0,75 m (18 kW),
approx. 1 m (27+36 kW)

Diameter of mill-wheel: approx. 1,20 m

Heater with an output of 27 KW upward-the mill wheel have to be installed onto a 60 mm high base.



MADE IN GERMANY

Dimensions

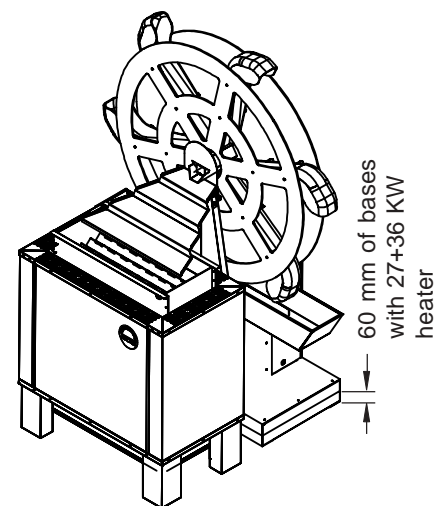
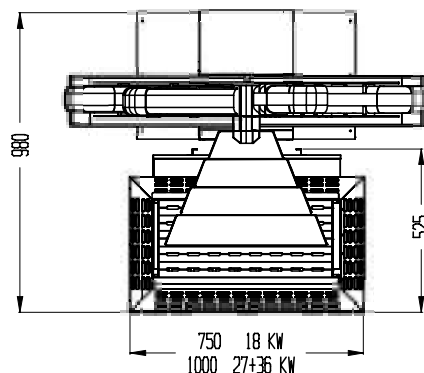
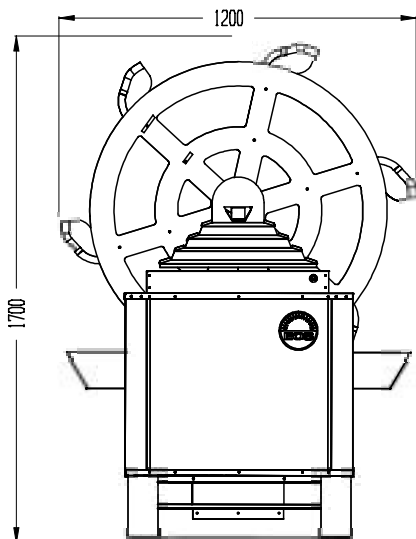

Program example with one turn-around time of 60 min

pause time	10%		10%		10%		10%	
Infusion	80%		80%		80%			
Signal 1 (Light: "Attention Infusion")								
Signal 2 (exhausts)								
Run time in minutes	55	1	0,33	1	0,33	1	0,33	1

Druck-Nr. 29342893 en 25.06

Technical subject to change