

Coloured light unit

FL 800 / 800 S

for fixing in IR-cabins

FL 800

Coloured light unit with 8 special fluorescent coloured light lamps each 8 W in red, yellow, green and blue. The unit can be fixed beneath the ceiling or onto the wall of an IR-cabin. Lamps and starters are easily accessible.

Safety glass cover with special grain for optimal light dispersion and resulting uniformly light irradiation in the cabin.

FL 800 S

Coloured light unit as described above but with four switches for each single coloured light lamp. Each switch controls a colour. Several lamps can be switched on simultaneously.

The coloured light unit can be operated using the coloured light control units 60 FL, 48 FL, ECON F1, EMOTEC C55, EMOTEC DC 9000, EMOTEC HIC 75* and EMOTEC HCS 9003*.

*) with modul colourlight upgrade

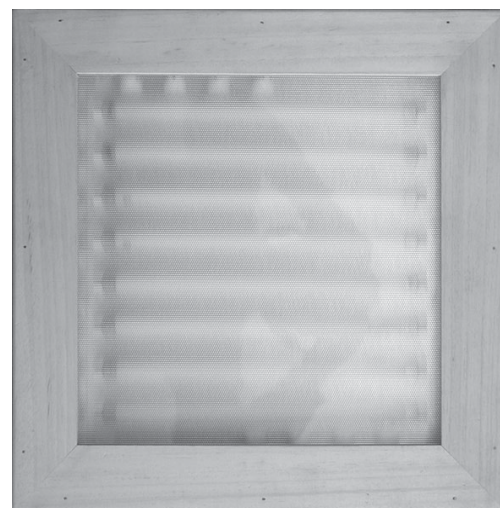

FL 800



MADE IN GERMANY

Drilling distances for assembling

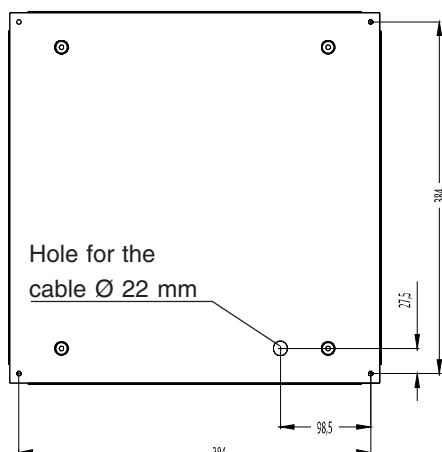

Technical Data

FL 800

8 special coloured light lamps each 8W
 Dimensions: LWD 445 x 445 x 56 mm
 Voltage: 230 V 1N AC 50 Hz
 Power consumption: 72 W
 Weight: approx. 8.0 kg

This unit has to be used with a coloured light control unit.

FL 800 S

8 special coloured light lamps each 8 W each lamp individual switchable, with inbuilt switch
 Dimensions: LWD 445 x 445 x 56 mm
 Voltage: 230 V 1N AC 50 Hz
 Power consumption: 72 W
 Weight: approx. 8,0 kg

The unit is ready to plug-in.

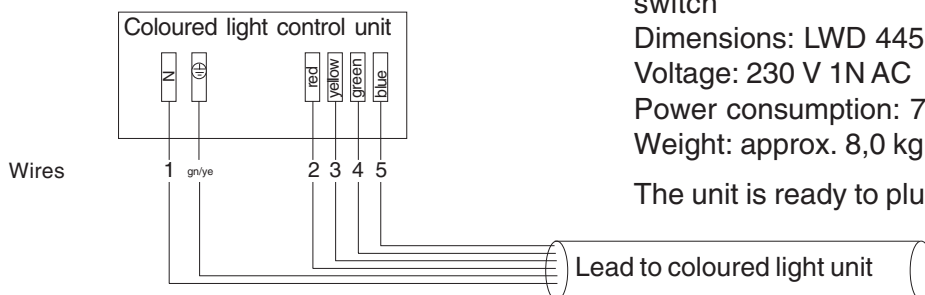

Subject to technical modifications