

Sauna heater Corona S25 vapor

For familysaunas

Free standing heater

Outer shell: The exterior design features a striking combination of straight lines, massive yet elegant steel with the raw sauna rocks. The internal and external shell is completely made of the best quality stainless steel.

Water container: for approx. 5 litres

Terminal box: high-grade steel

Stone filling: 25 kg incl.

Service friendly unit assembly system
The heating elements are mounted on a rack and may be conveniently removed without the need to remove the rocks. Optimised ratio of radiated heat and convection due to the appropriate amount of stones.



CE IP X4
MADE IN GERMANY

Connection diagram

7,5 - 9 kW

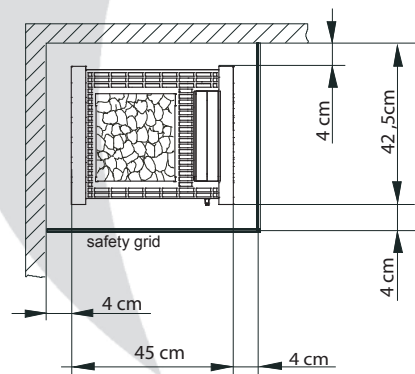
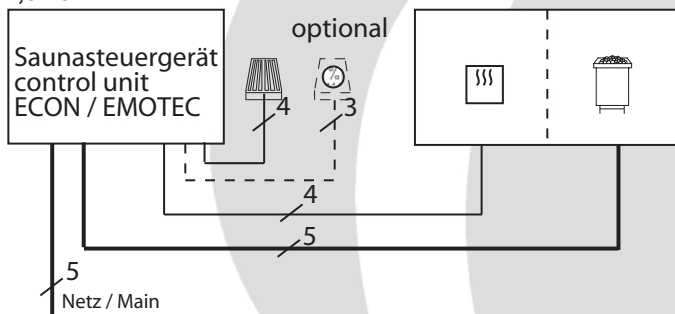

| Heater power acc. to DIN | Evaporator power | Haeter dimensions (H/W/D) in cm | For cabin volume | Minimum dimension for ventilation and bleeding | Weight without stones and packaging | Stone filling | Electr. connection | Control unit fuse in A | Connection mains - control unit | Connection control unit - heater | to be used with the control units |
|--------------------------|-------------------|---------------------------------|------------------------|--|-------------------------------------|---------------|-------------------------|------------------------|---------------------------------|----------------------------------|--|
| 7.5 kW | 2.0 kW ca. 5 l | 75 / 44 / 38.5 | 8 - 12 m ³ | 35 x 5 cm | 55 kg | 25 kg | 3N AC 50 Hz 400 V | 3 x 16 | 5 x 2.5 | 5 x 1.5 & 4 x 1.5 | EMOTEC HCS 9003 EMOTEC HCS 9003 DB/DL/DF EmoTouch II PB/AF/GF |
| 9.0 kW | | | 10 - 14 m ³ | 35 x 6 cm | | | | | | | |

All information on cable diameters are minimum diameters in mm² copper line.