

ELECTRIC SAUNA OVEN

Typ 38.AS

Outer casing in enamelled sheet steel in sepia conforming to RAL 8014. Fire-aluminized sheet metal inner casing in "floating" design to avoid cracking noises. Galvanized sheet steel back panel and exterior connection terminal box. Floor panel in drip tray design. High-alloyed steel stone grate and cover frame. Low surface stress on stainless and scaling free heating elements which are easily interchangeable. Includes 15 kg unit of natural sauna stones. Recommended for family saunas. Built-in capillary tube thermostat and limiter. Heating period 4 hrs.

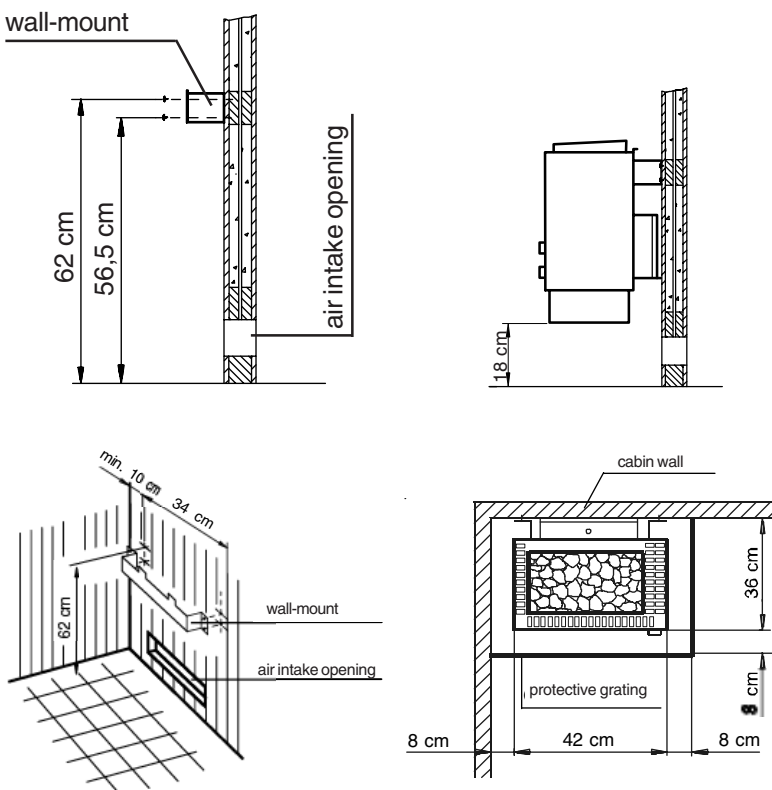

connection diagram for 7,5 kW oven (with 6 kW 3 tubular heating elements with 2000 W each)

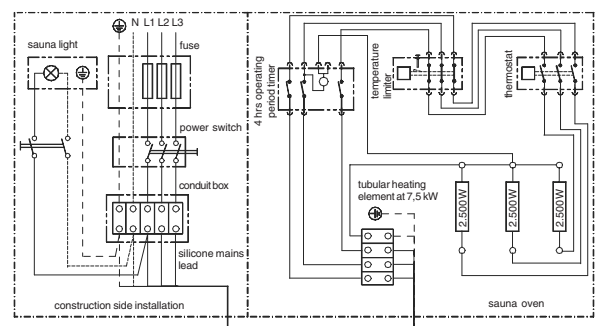

art.-no.	capacity	electr. connection	installation dimensions H/W/D in cm	suitable for cabin volumes	minimum ventilation size	weight (excl. packing)	stone filling	outer casing
94.2376	6,0 kW	400 V 3N AC 50 Hz	71/42/36	6 - 8 m ³	35 cm x 4 cm *)		15 kg	sepia RAL 8014
94.2377	7,5 kW	400 V 3N AC 50 Hz	71/42/36	7 - 10 m ³	35 cm x 5 cm *)		15 kg	sepia RAL 8014

*or according to cabin producer's specification

Subject to technical modifications