

*emotion of sauna.*



**Assembly instructions and  
instructions for use**

# Infrarot-Strahler VITAE

**PHILIPS**  
 **INFRARED**



GB



Druck Nr. 29342328en / 33.06





**PHILIPS**  
**INFRARED**



### Important notice

**There is a fire risk if assembled incorrectly. Please read these assembly instructions carefully. Take special note of the measurement details and the following notes.**

- The infrared thermal emitter is intended for a connection voltage of 230 V 50 Hz via an infrared controller.
- Assembly and connection to the infrared controller must be carried out in accordance with the connection diagram (Fig. 11).
- Before the emitter is operated via the controller, check that all connectors are firmly connected with no risk of coming loose.
- The EU 60335-2-53 (VDE 0700 Part 53) regulations are to be complied with inside the infrared booth.
- Only the number of emitters specified for the size of the booth should be assembled in the infrared thermal booth.
- One of the controllers specified below should be used to regulate or control the infrared emitter. This controller should be fixed to the infrared thermal booth in accordance with the assembly instructions.
- **Attention: Covering the infrared thermal emitter causes a fire risk!**
- The assembly of the infrared emitter in the booth must be carried out in such a way to assure even all-round emission for the sauna frequenter.
- The infrared thermal emitter is not suitable assembly on the booth ceiling and must not be mounted there.
- If the infrared thermal emitter is assembled in the rear area, then appropriate protective measures must be taken to ensure that the flocked protection grille cannot be pressed in unintentionally (e.g. a wooden grille mounted in front).
- Take care to ensure that the main energy discharge occurs through the infrared radiation.

Additionally, however, a thermal heat discharge arises at the housing in the vertical assembly. This heat can stress the emitter thermally! **Caution: fire risk!**

Ensure that this hot convection air can escape by rising freely.

If necessary, appropriate steps should be taken (e.g. thermal protection slabs) to ensure that the wood is not exposed to inadmissible temperatures.

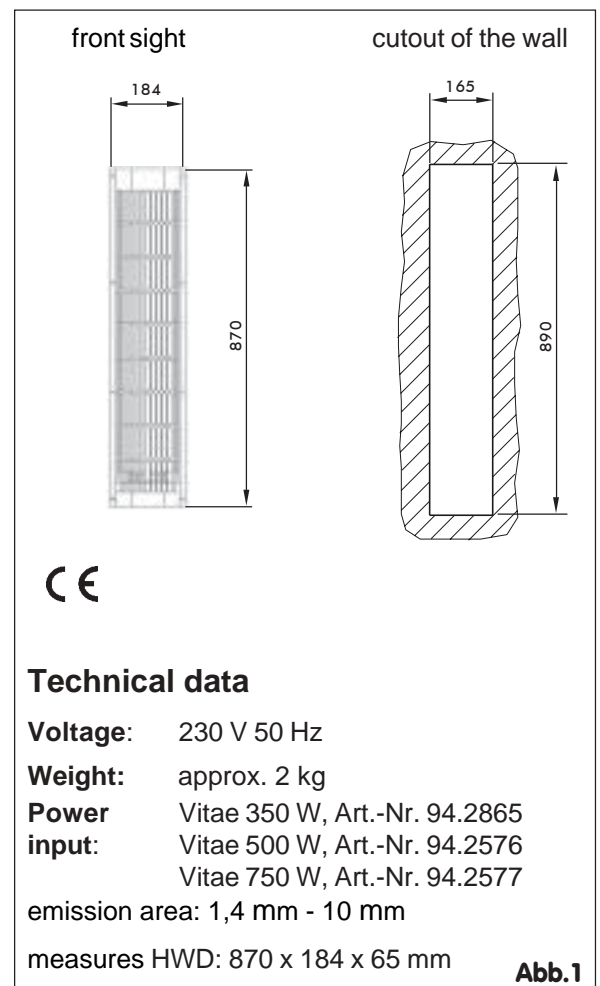

- The infrared thermal emitter is equipped with a silicon connection cable with a 3-pin connector. This connector is joined to the connector of the infrared controller with a free outlet.

**Care must be taken to ensure that the earth is properly tight.**

- Up to 5 infrared thermal emitters may be connected to this socket distribution.

For practical reasons, the connector should be fitted to the booth ceiling.

- **Take care to ensure that the special ceramic emitter is not subject to any mechanical stresses (knocks, pressure). Risk of breakage.**

Although breakage is unlikely if it is used properly, if the ceramic emitter should break, replace it with a new one.

- recommended distance is 50 cm between human and IR-emitter.

**Attention!**

If there is any skin disease or illness, you should ask a doctor before using.

**Assembly**

**Caution!**

Remove the transport stabilisers from the Vitae-emitter, loosening the covering grille. Remove the foamed pad. Take care that the Vitae-emitter does not be damaged.

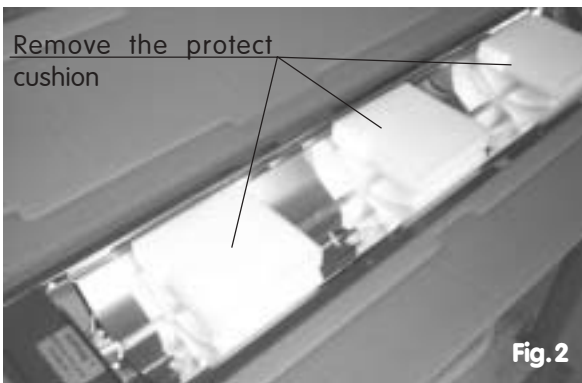

Fig. 2

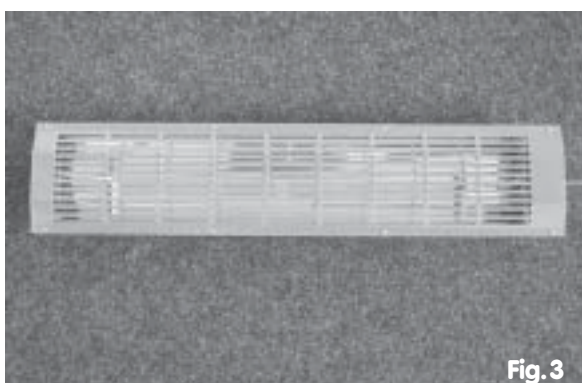

Fig. 3

The emitter should be assembled in such a way as to ensure that the body of the sauna frequenter radiates over as large an area as possible.

Assembly in the four corners of the infrared booth is recommended.

**Assembly example:**

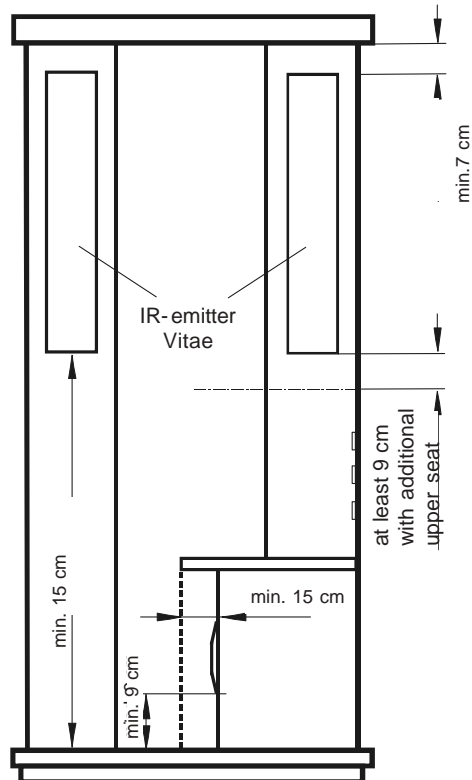

Fig. 4

**Mounting example in the sauna cabin with additional upper bench.**

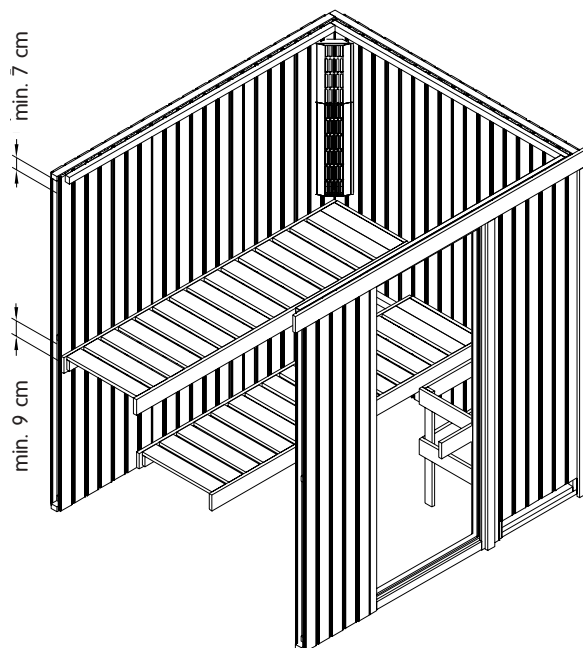

Fig. 5

Recommended distance between human and emitter is approx. 50 cm (see fig. 6).

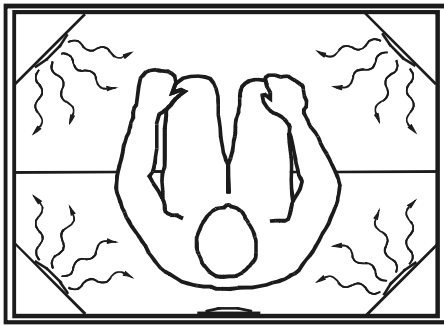

Fig. 6

For assembly, a right-angled opening of 890 x 165 mm must be fitted vertically into the wood.

must be fitted vertically into the wood.

The emitter can then be assembled with the enclosed chipboard screws (see Fig. 7 and 8).

## Positioning of the infrared emitters

vertical assembly on the booth wall

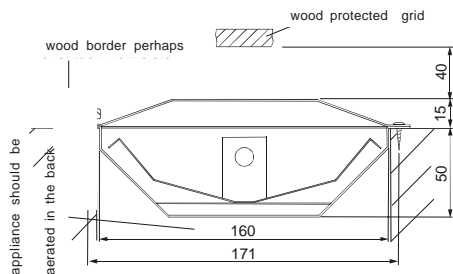

vertical assembly in the booth corners

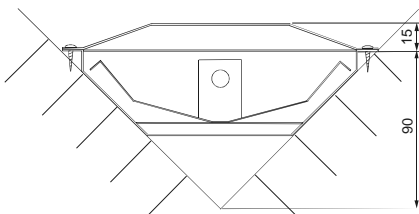

### ● Minimum distances

The minimum distance from the emitter upper edge to the booth ceiling must be 7 cm.

The minimum distance from the emitter lower edge to the wooden floor of the booth must be 9 cm

The horizontal minimum distance between the emitter and all combustible parts must be 4 cm.



### Very important!

In the case of vertical assembly (connection always upwards or in accordance with the booth manufacturer's specifications), the area above the emitter should not be encased with wood in front (Fig. 9). Hot air rising when the housing is heating must be able to escape freely. Fire risk!

In the case of horizontal assembly in the area of the nets (net emitter), the emitter may not be covered by objects such as towels, and must be made safe if necessary by fitting an additional wooden grille. Fire risk!



Fig. 9

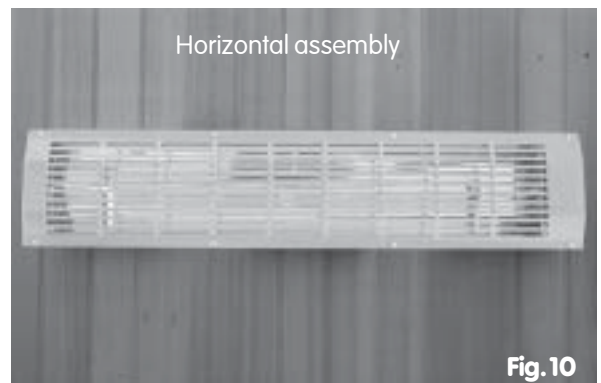

Fig. 10

Fig. 7

### Caution!

For assembly of the net emitter, the measurements specified in Fig. 4 must be complied with.

## Electrical connection

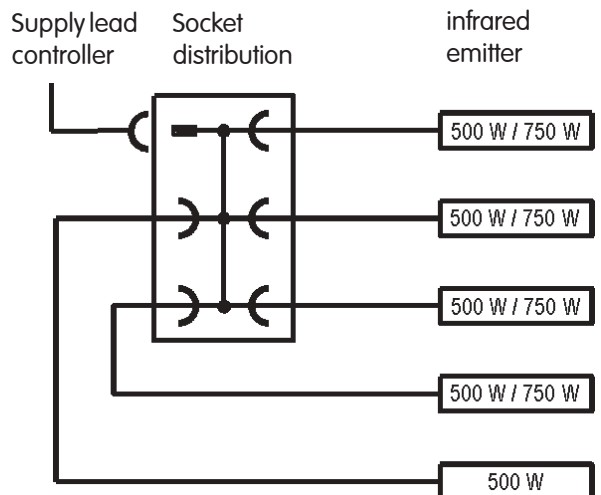
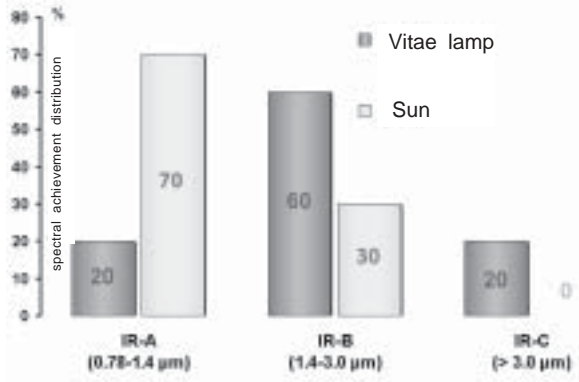

Fig. 8

Max. 4 pieces for 750 W per emitter (3500 W) Fig. 11

**spectral achievement distribution**

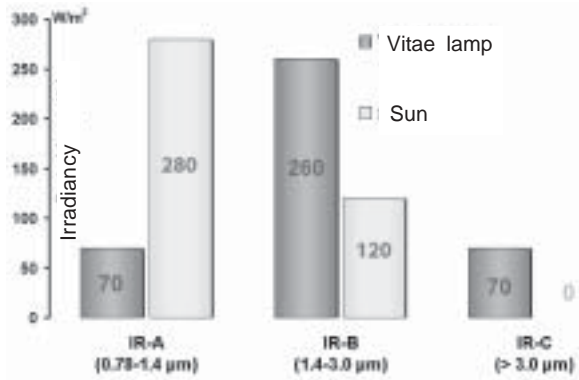

**Fig.12**

The IR-emitter is designed for mounting in a IR-warm cabin or sauna only. It just can be used with a controller. The warranty is not to apply for other use.

Service address:  
 EOS-Werke Günther GmbH  
 Adolf-Weiß-Str. 43  
 35759 Driedorf-Germany  
 tel +49 (0) 2775 82 240  
 fax +49 (0) 2775 82 455  
 servicecenter@eos-werke.de  
 www.eos-werke.de

**Irradiancy**



**Fig.13**

**Guarantee**

The guarantee is taken over according to the legal regulations at present.

**Manufacturer's warranty**

- The period of warranty starts from the date of purchase and lasts up to 2years for commercial use and 3 years for private use.
- Always include the completed warranty certificate when returning equipment.
- The warranty expires for appliances which have been modified without manufacturer's explicit agreement.
- Damages caused by incorrect operation or handling through non-authorized persons are not covered under the terms of warranty.
- In the event of a claim, please indicate the serial number as well as the article code number and type name with expressive description of the fault.
- This warranty covers damaged parts but no defects due to wear and tear.

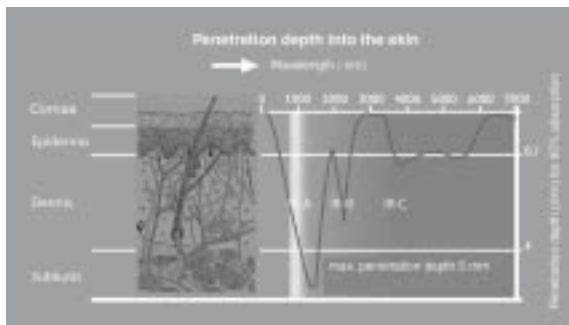

**Fig.14**



For a too long time looking in the emitter, your eyes can be damaged.

**Fig.15**

In case of complaint please return the equipment in its original packaging or other suitable packaging (caution: danger of transport damage) to our service department.

Always include the completed warranty certificate when returning equipment.

Possible shipping costs arising from the transport to and from point of repair cannot be borne by us.

Outside of Germany please contact your specialist dealer in case of warranty claims. Direct warranty processing with our service department is in this case not possible.

Equipment start-up date:

Stamp and signature of the authorized electrician: